

Mamba™ 功能使用說明書



承重 100 kg



氣壓升降



椅背3段後仰



頭枕升降調整



頭枕角度調整



扶手升降調整



扶手前後調整



扶手左右調整



靜音椅輪



頭枕操作說明

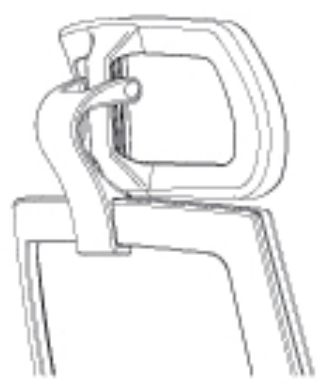

操作方式

向上/向下調整高低

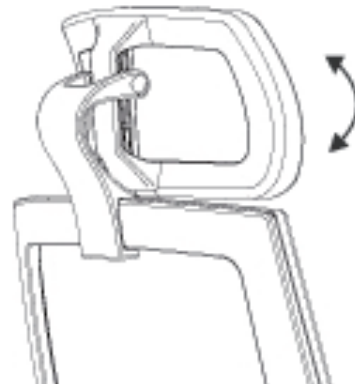

操作方式

向上/向下調整角度



建議至少每三個月檢查並重新鎖緊所有螺絲和零件。

如果有螺絲或零件鬆脫，請重新鎖緊後再使用，以確保安全。

扶手操作說明

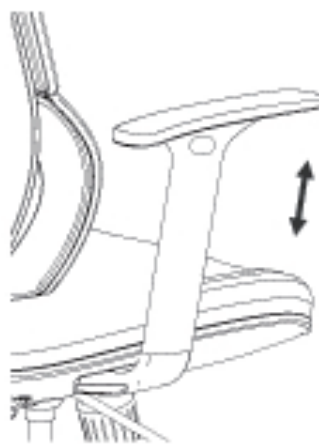

操作方式

按壓扶手墊下的按鍵
調整扶手升降

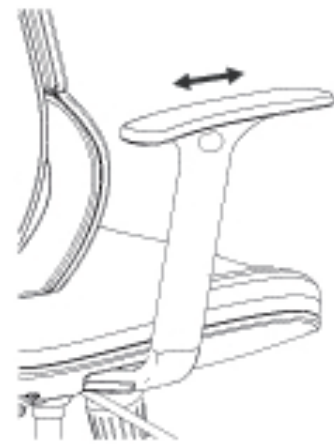

操作方式

推-扶手墊前後調整



操作方式

轉-扶手墊扇形調整

頭枕鬆緊調整說明

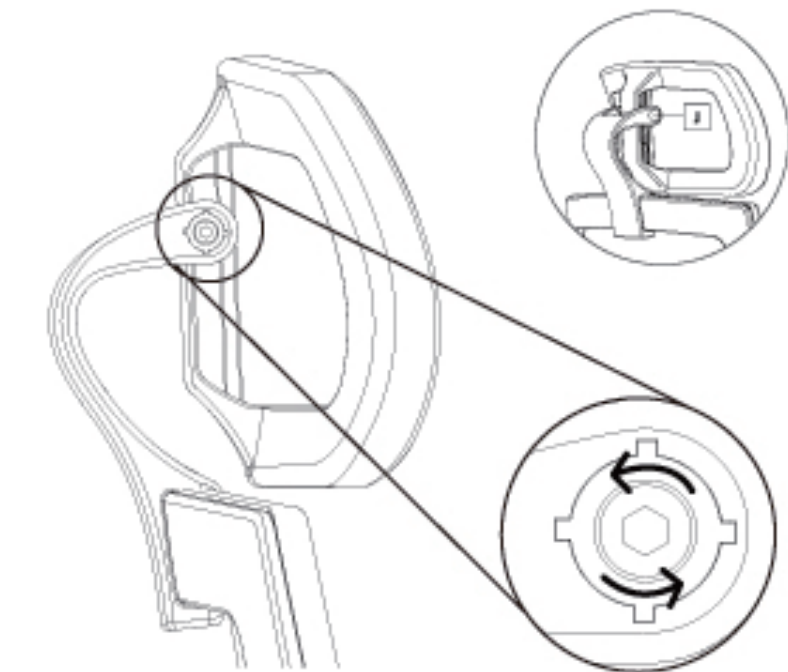

操作方式

順時針(勿超過3圈) - 調緊頭枕
逆時針(勿超過3圈) - 調鬆頭枕

椅背後仰&升降操作說明

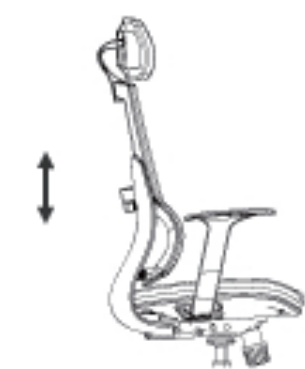

操作方式

向上扳起控制桿
調整座椅升降
向外拉開控制桿
開啟椅背後仰功能
向內推進控制桿
鎖定椅背後仰角度

椅背後仰鬆緊說明

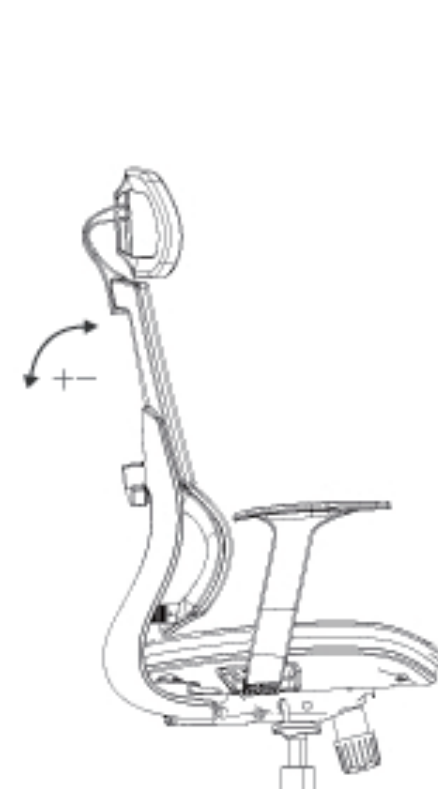











調整椅背後仰力道

1. 順時針轉動
後仰力道小
2. 逆時針轉動
轉緊後仰力道大

Mamba™ 功能使用說明書

零件清單

A  左扶手 x1	B  右扶手 x1	C  坐墊含底盤 x1	D  扶手螺絲 x6
E  椅背 x1	F  椅背螺絲 x3	G  氣壓棒 x1	六角板手  x1
H  椅腳 x1	I  PU靜音椅輪 x5	J  飾蓋 x1	TIPS : 在安裝飾蓋(J)之前,可先測試頭枕鬆緊度,如太緊可參考背面的調整頭枕鬆緊度說明。



! 建議至少每三個月檢查並重新鎖緊所有螺絲和零件。
 如果有螺絲或零件鬆脫,請重新鎖緊後再使用,以確保安全。

組裝說明

STEP 1

 建議將椅子放置在紙箱或桌面上更加方便組裝!

 組裝前請確認螺絲與配件是否備齊,一經組裝將影響退貨權益。

STEP 2 : 安裝左右扶手

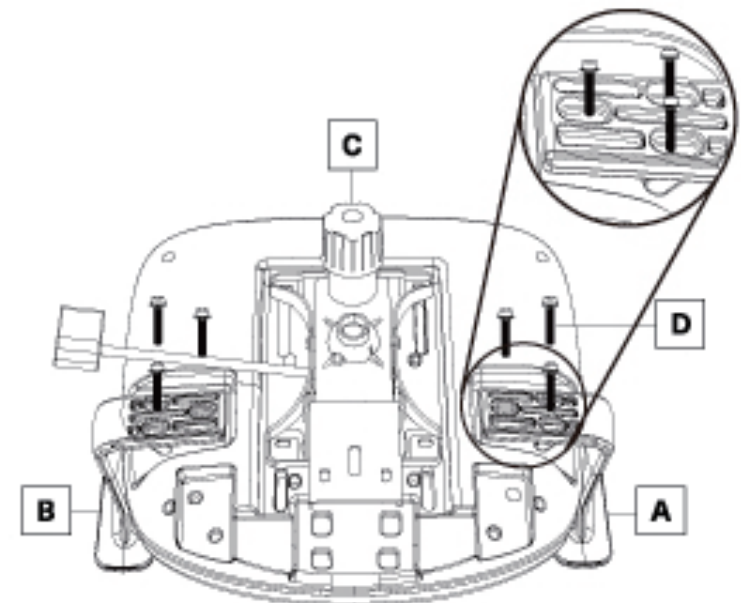

STEP 3 : 椅墊 & 椅背結合

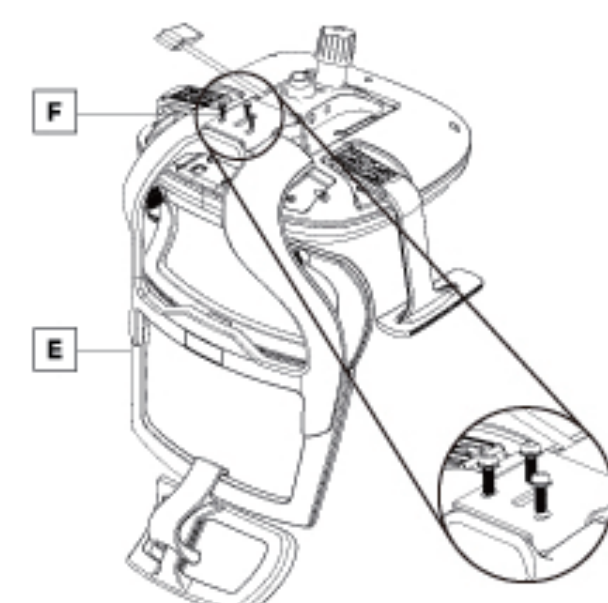

STEP 4 : 氣壓棒插入底盤

TIPS : 氣壓棒直接插入底盤中心孔內。

! 記得先拔除氣壓棒紅色保護蓋後,再行組裝。

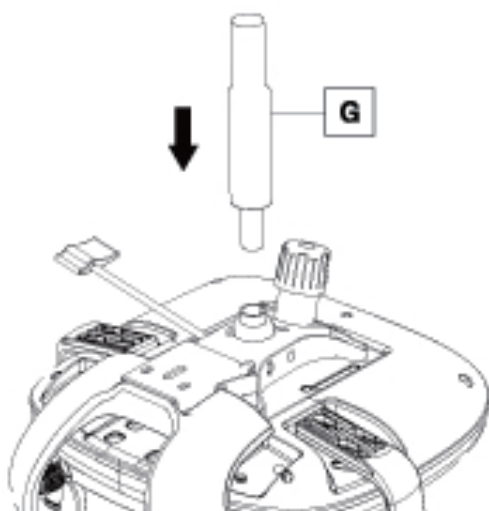

STEP 5 : 安裝椅輪

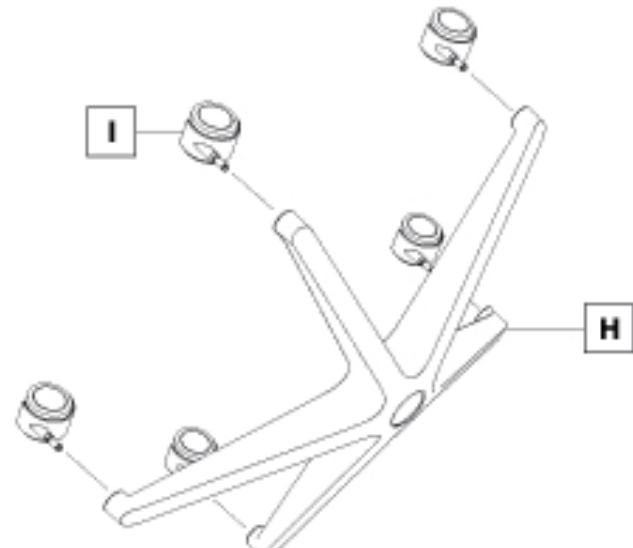

STEP 6 : 氣壓棒插入椅腳

